

## ASSEMBLY INSTRUCTIONS FOR THROUGH-PANEL KIT

### SINUS PENTA S22 - ZZ0124931

- 1) Check if the KIT supplied contains all the components given in the list on page 2/5.
- 2) Prepare the SINUS PENTA S22 drive (page 3/5) for the assembly of the THROUGH-PANEL KIT - ZZ0124931.
- 3) Mount part “A” on the drive, see Figure 2 (page 4/5), making sure not to fully tighten the screws (“G”).
- 4) Mount part “C” as explained in step 3 (see Figure 3, page 4/5). Make sure not to fully tighten the nuts (“H”).
- 5) Following Figure 4 (page 5/5), assemble the two parts “B”. The figure shows only one of the drive sizes because the opposite size is symmetrical to the one shown in the figure. Insert all the screws shown in the figure without fully tightening them.
- 6) Tighten screws “D” of parts “B”; make sure that they are fully in contact with the enclosure wall. The maximum tightening torque is 30NM.
- 7) Tighten all screws “G” and their nuts “H” allowing assembling parts “A”- “B”- “C” together (see Figure 4), making sure that they form the wall bearing surface. The bearing surface shall have a slot for the through-panel assembly, where the drive will be fastened to. The surface between the junction points in the parts forming the assembly kit must be perfectly smooth. M6 screws and nuts are to be tightened with a maximum torque of 10 NM.
- 8) Tighten the screws and nuts for parts “A” and “C” (previously left loose in steps 3 and 4 above) to the drive enclosure. The maximum tightening torque for M6 screws and nuts is 10 NM.
- 9) Assembly is now complete and the drive is ready to be fastened to the wall. Notice that the mounting wall is to be prepared beforehand following the instructions given in the Installation Guide for the Sinus Penta S22 (see section “Through-Panel Assembly and Piercing Templates”).

COMPONENTS LIST  
MECHANICAL LIST

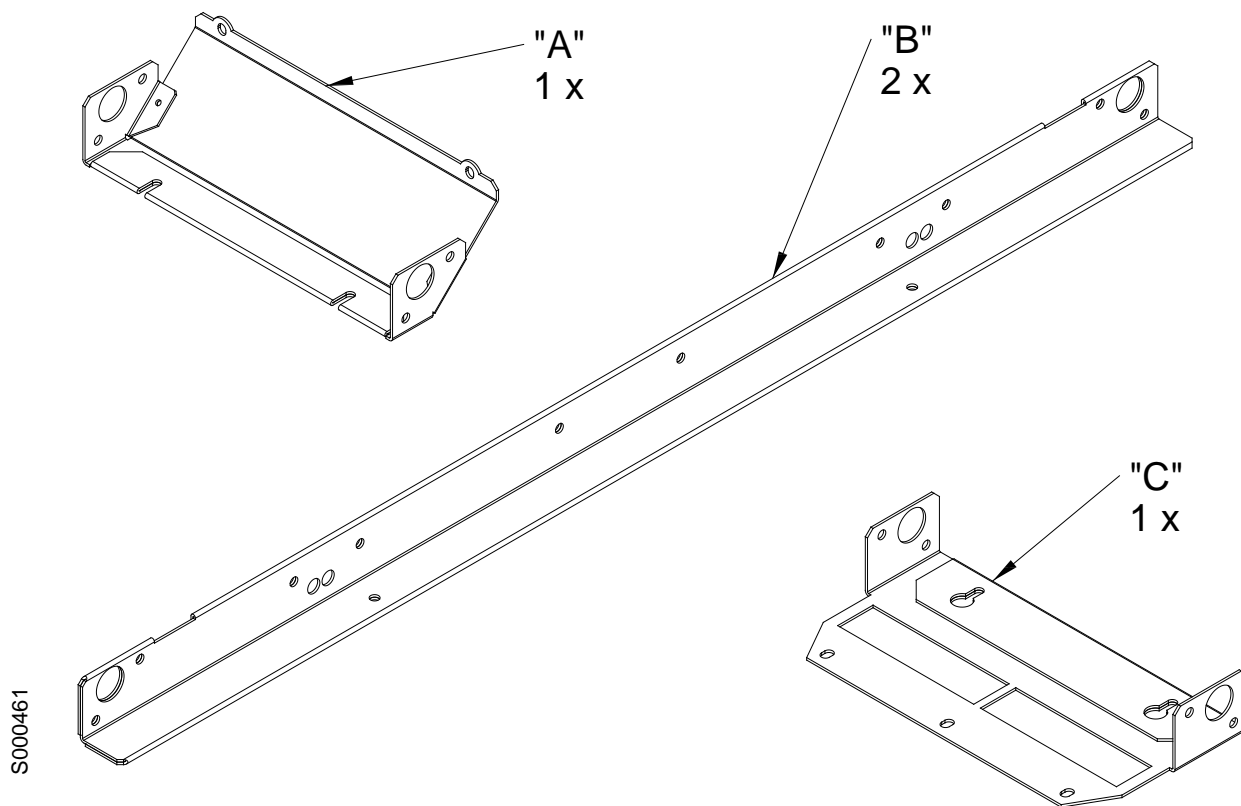

SCREWS

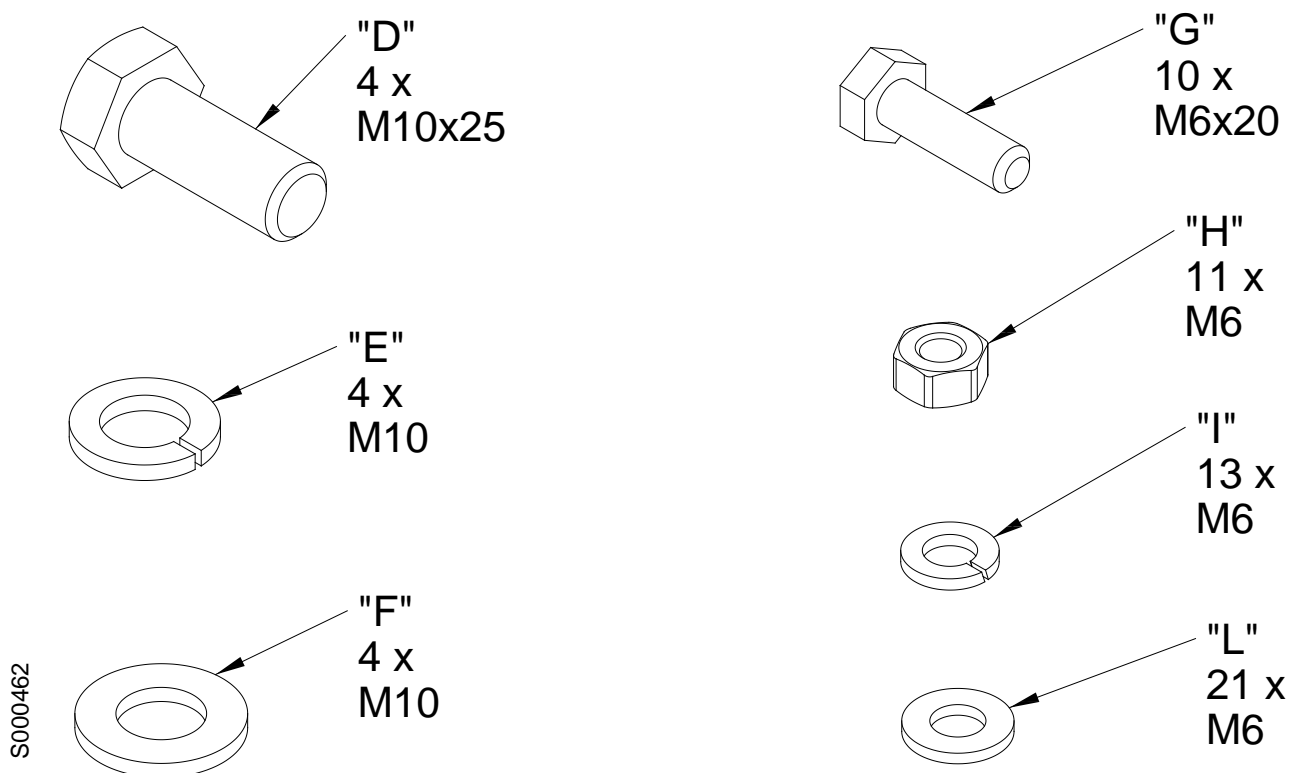

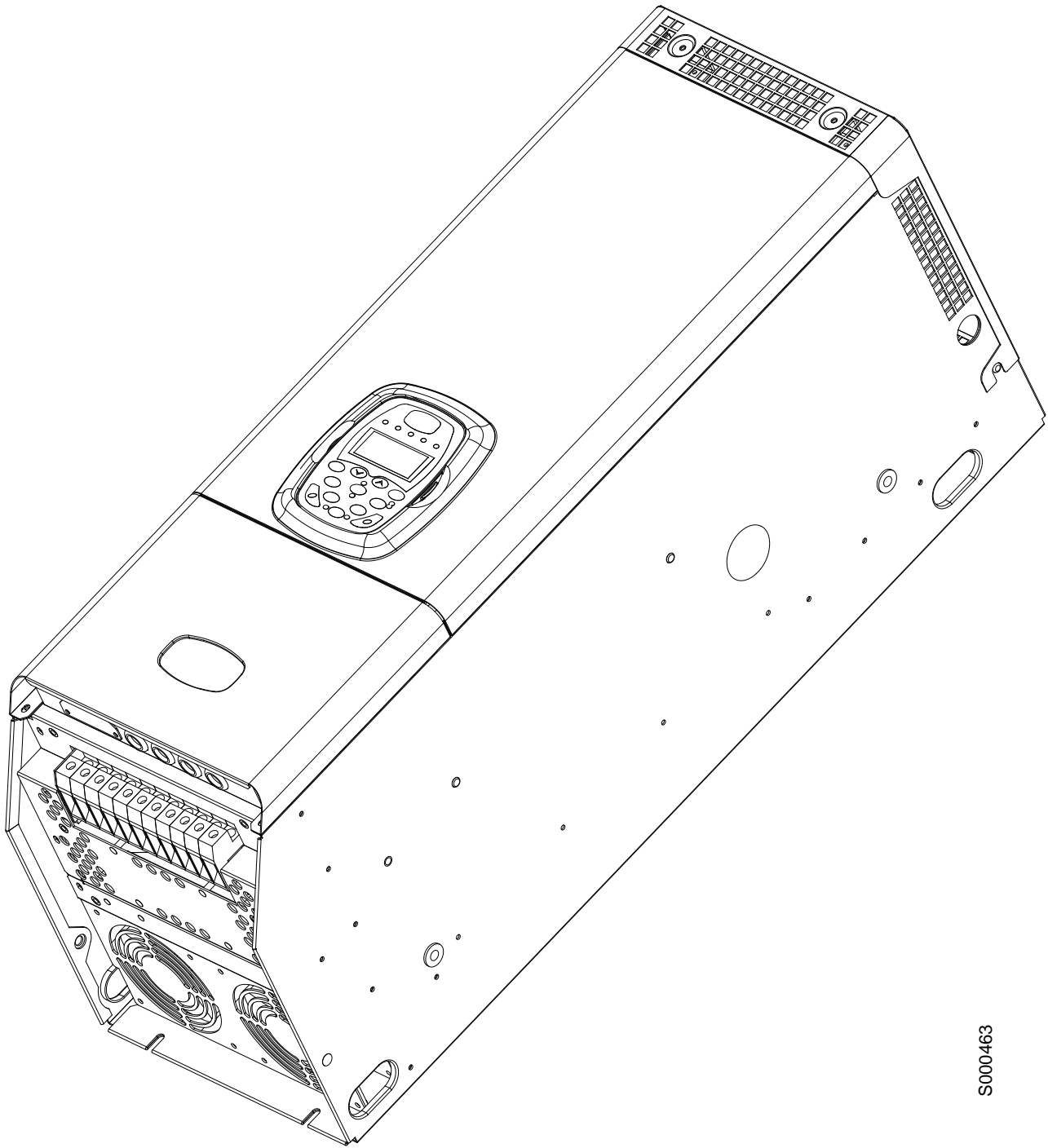

S000463

**Figure 1: Sinus Penta S22 – Drive**

S000464

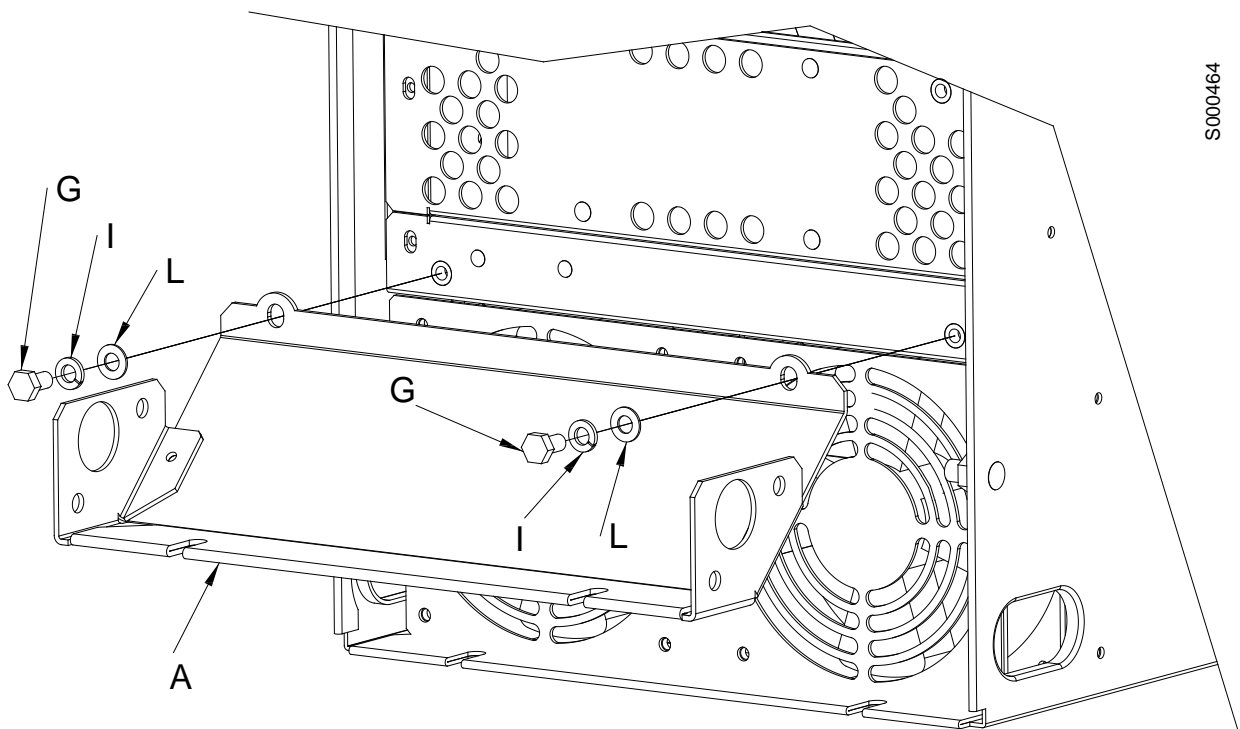

Figure 2: Assembly instructions for part "A"

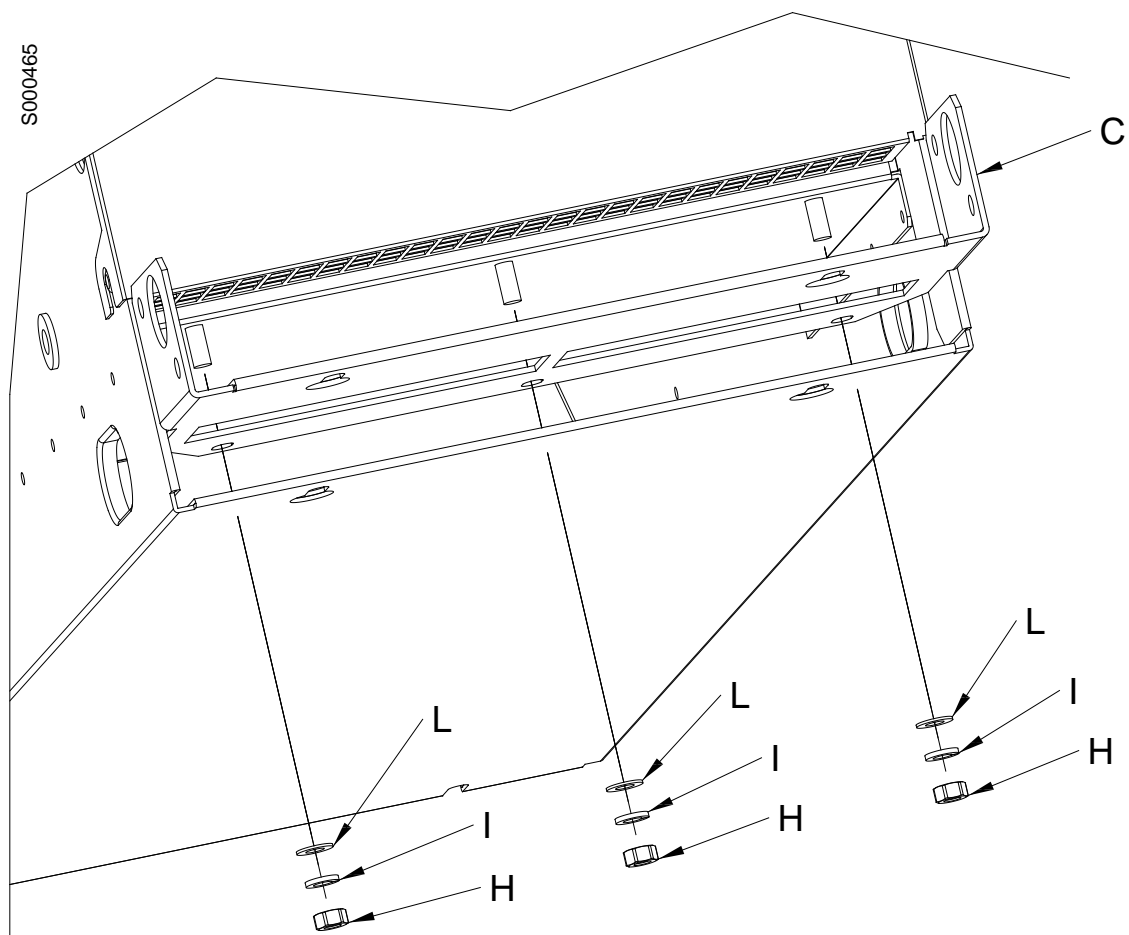
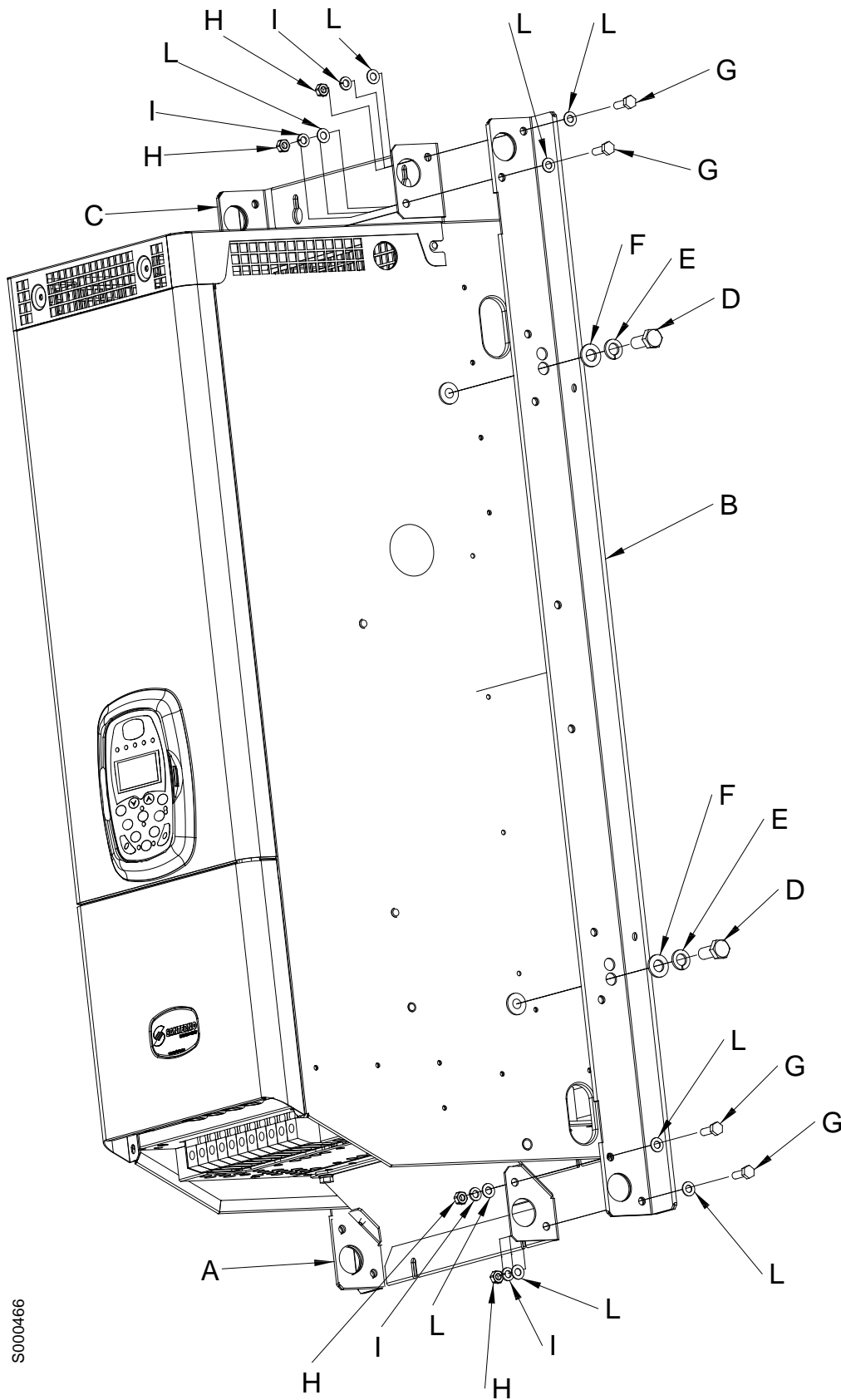

Figure 3: Assembly instructions for part "C"



S000466

**Figure 4: Assembly instructions for part "B" (2 pieces)**

*NOTE: The figure above also applies to part "B" to be mounted on the opposite side.*